

ODL-3-340300-342SB0

Optidrive Elevator Core VFD Datasheet

15 kW (20 HP), 30 A, 380-480 V, 3PH
IP20 Variable Frequency Drive with EMC
Filter



Input Ratings

Supply Voltage	380-480 V
Input Phases	3
Supply Current Continuous	A
Supply Fuse or MCB (Type B)	A

Output Ratings

Motor Output Rating	15 kW (20 HP)
Output Voltage	0 – Supply Voltage
Output Current	30 A

Cable Information

Max Supply Cable Size	–
Max Motor Cable Size	–
Max Motor Cable Length	100 m (328 ft)

Factory Build Options

EMC Filter	Internal EMC
Brake Transistor	Internal
Enclosure	IP20
Display	LED
PCB Coating	Full Conformal

Dimensions

Size	3
Height	261 mm (10.28 in)
Width	131 mm (5.16 in)
Depth	207 mm (8.15 in)
Weight	3.72 kg (8.2 lbs)
Fixings	4xM5

Packaged Dimensions

Height	242 mm (9.53 in)
Width	165 mm (6.5 in)
Depth	364 mm (14.33 in)
Weight	4.34 kg (9.57 lbs)



 **Buy this drive or get more information**
Find your local sales partner on
invertekdrives.com



The following document provides a summary of the Elevator Core drive's compliance, protection and feature set supported.

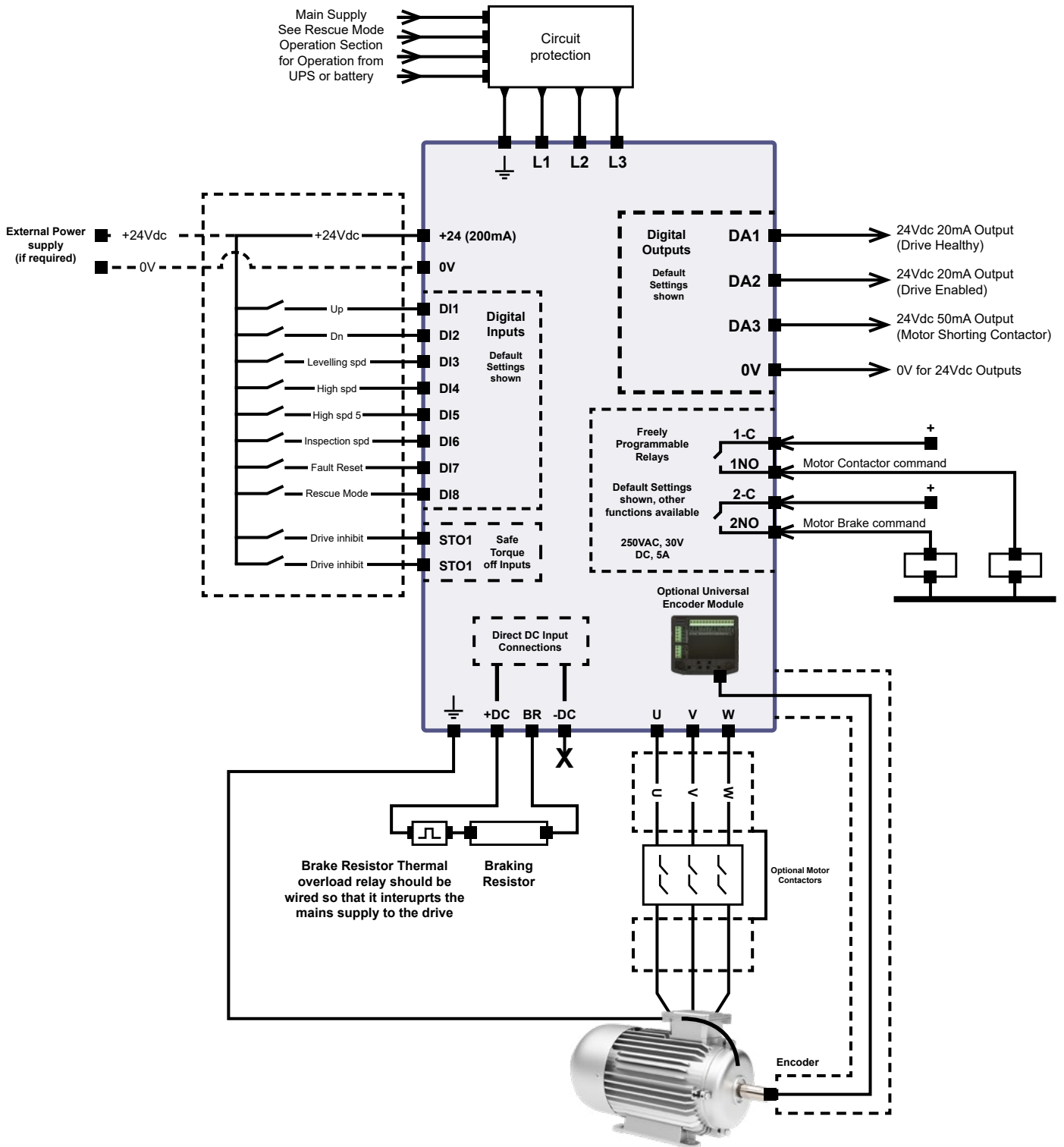

Drive Specification & Features

Compliance and Certifications	<ul style="list-style-type: none"> European product certification EN 61800-5-1 European product certification UL 61800-5-2 (Functional Safety) European EMC standards EN61800-3:2004 USA product certification UL 61800-5-1 USA product certification UL 61800-5-2 (Functional Safety) *USA Lift standard ASME A17 Dual Safe Torque input according to EN 61800-5-2, SIL 3 *certification by TÜV Brake Contact Monitoring (Unintended Car Movement) EN 81-20:2014+A3 certification by Lift Institute Without Motor contactor conformity using Safe Torque Off inputs according to parts of EN 81-20:2014 and EN 81-50:2014 *certification by Lift Institute 	Elevator Drive Software Features	<ul style="list-style-type: none"> Elevator industry menu structure 200% overload capability Frequencies up to 10 kHz @50°C (full load no de-rating throughout travel curve) Roped static Autotune. PC Tool support > Programming, Setup, Monitoring, Backup, Scope, Trip Eliminator USB C connection and mobile device/PC APP support Analogue and Digital control (NPN/PNP Logic) Control terminal assignment macro system or user definable to match elevator controller. Trip log time stamping Fault detection suppression. Built in flight recorder Analogue, Binary, Priority control, Control word Analogue follower mode. User adjustable Contactor sequencing Full travel profile setting and user stop profile configuration Floor sensor correction Multiple speed and current loop gains Current loop and Encoder speed feedback filters Anti-rollback compensation (DC Injection, Position Lock, Load-Cell Input) Smooth Start function. Creep to Floor operation Short Floor Operation *Direct to Floor operation Multiple speed and current loop gains Current loop and speed feedback filters Jerk Adjustments Low voltage Battery operation from 36Vdc up to drive rated Vdc Load measurement for rescue operation (Light Load Detection), Torque test, last run memory. Gravity Mode User Unit Selections Overspeed Governor Test Early Door Opening Anti-Stall Protection Travel Counter Rope-wear Counter User customisable Cooling Fan Control Output Phase Sequence swap. DC Bus connection support of regenerative units OEM Defaults. 	Environmental Ratings	<ul style="list-style-type: none"> Minimum Temperature -10°C Maximum Temperature (No Derating Factor) (UL Approved) 50°C Minimum Storage Temperature -40°C Maximum Storage Temperature 60°C Maximum Altitude (No Derating Factor) 1000 m Maximum Altitude (Derating Factor of 1% per 100m after 1000m) UL Approved 2000 m Maximum Altitude (Derating Factor of 1% per 100m after 1000m) Non-UL Approved 4000 m IP Class IP20 Relative Humidity <95% non-condensing Long life fans
Elevator Motor Control	<ul style="list-style-type: none"> Open and Closed Loop Geared motors Closed Loop Gearless motors Open Loop Gearless (Encoder Fault finding, Commissioning only) Built-in full rated Braking transistor throughout all ratings. 				
Elevator Drive Protection	<p>The following protection and monitoring features are built into the Optidrive Elevator Core drive as standard.</p> <ul style="list-style-type: none"> Motor Contactor Closing delay time Motor Contactor feedback state check Brake channel over current Brake resistor thermal overload software protection. Brake resistor thermal switch support. Motor short circuit protection in all situations. Motor thermal overload protection. Output phase loss detection. Drive reverse powering protection. (mains power connected to drive output). Over voltage on DC bus Under voltage on DC bus Input phase loss trip Input Phase imbalance (DC Bus Ripple) Over temperature Under temperature Ambient Temperature too High Multiple on-board thermistors, Within Power device, Control circuit, Power circuit. Motor PTC monitoring. Motor KTY monitoring. External trip input Control signal loss detection Communications loss Fault detection Heatsink Cooling Fan fault detection Safe Torque off circuit Error detection Encoder Feedback Faults Autotune Error detection Factory Default parameters have been loaded Brake Release Monitoring Brake Release Monitoring Lockout Modbus comms fault CAN Open comms trip Service Timer 		Encoder support		
			<ul style="list-style-type: none"> Universal Encoder module. Encoder wire break detection. Encoder direction swap. Encoder offset real-time feedback. Encoder Feedback shaft copy, simulated Encoder output. Incremental HTL, TTL single and quadrature type Encoders. Absolute Encoder support, Endat, SinCos *Biss. 		



Buy this drive or get more information

Find your local sales partner on invertekdrives.com

How we measure our drives and packaging

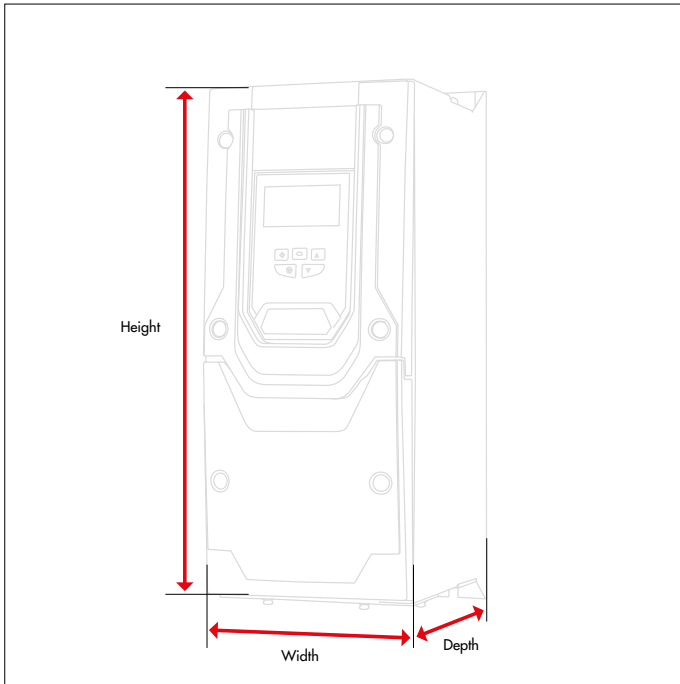

Drive Dimensions

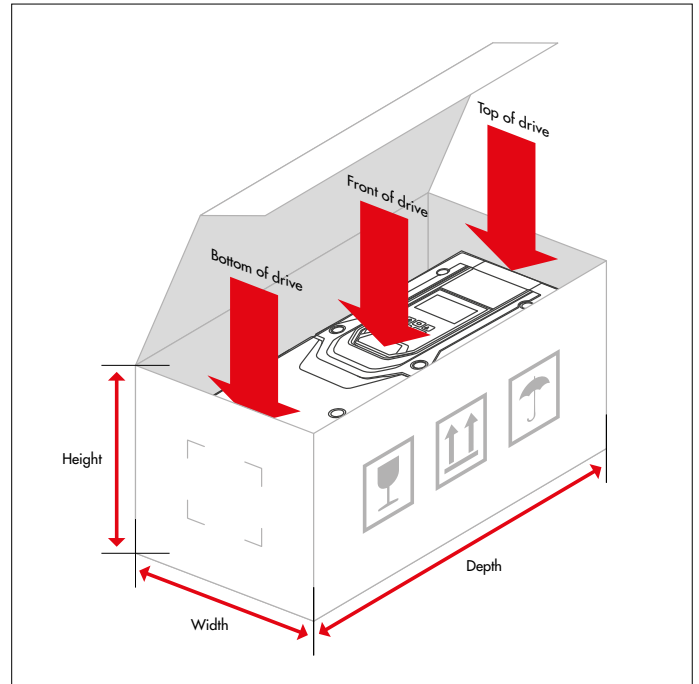

Packaging Dimensions



Buy this drive or get more information

Find your local sales partner on
invertekdrives.com

